

TEST- AND MEASURING INSTRUMENTS FOR TREES AND TIMBER STRUCTURES

(Drilling Resistance Measurement)

IML RESI F300
F400
F500

IML-RESI made in Germany by:

IML-Instrumenta Mechanik Labor System GmbH
Großer Stadtacker 2
69168 Wiesloch
-Germany-

Phone: +49 (0) 6222 6797-0
Fax: +49 (0) 6222 6797-10

E-mail: info@iml.de
Website: www.iml.de

Imprint



The information contained in the present manual instruction has been prepared most thoroughly. Errors or mistakes can, however, not be excluded. IML-Instrumenta Mechanik Labor System GmbH will not assume any legal responsibility nor any liability for the consequences of such errors or mistakes. The present information may be modified without notice. IML System GmbH reserves the right to make modifications to the instruments for better technical functioning, capacity and longevity. Any kind of reproduction or processing by means of electronic systems, or distribution of the present or any part of it without prior written approval of IML-Instrumenta Mechanik Labor System GmbH is strictly prohibited.

Manufacturer:

IML-Instrumenta Mechanik Labor System GmbH

Großer Stadtacker 2
69168 Wiesloch
Germany

Phone: +49 (0) 6222 6797-0
Fax: +49 (0) 6222 6797-10
E-mail: info@iml.de
Website: <http://www.iml.de>

Seat and District Court: HRB 701885 District Court Mannheim
USt.-ID. No.: DE 254022201
Managing Director: Erich Hunger

© 2008 IML-Instrumenta Mechanik System Labor GmbH. All rights reserved.

CONTENT

INTRODUCTION	Page
Notes to application	-4-
Materials	-4-
Certainty of reading	-4-
General	-4-
Conception	-4-
Structure of the system	-4-
Moisture	-4-
Preservation of drilling needles	-4-
Maintenance	-5-
Guarantee conditions	-5-
Instructions for utilization	-5-
Safety instructions (Safety notes for your own safety)	-5-
INSTRUCTION FOR USE	-6-
Basic equipment	-6-
Application	-7-
How to hold the drilling instrument	-7-
Examination of wooden poles	-7-
Execution of a measurement	-7-
Preparation of the measurement	-7-
Execution of a measurement	-7-
Pre-adjustments	-8-
Adjusting the advanced speed stage of the accumulator drill	-8-
Adjusting the sensitivity	-8-
Sensitivity stages	-8/9-
Table of approximately values	-9-
Insert or exchange a wax paper strip	-10-
Exchanging the drilling needle	-11/12-
MAINTENANCE WORKS	-13-
Lubrication of the gear wheels	-13-
Replacing the safety pin	-13-
Overload clutch	-14-
Adjusting the overload clutch by means of the sickle spanner	-14-
Adjusting the overload clutch by means of the torque wrench	-15-
Exchanging the clutch disks	-16-
Mounting the paper magazine	-17-
Mounting the 45°-adapter, rotatable	-18-
Attaching the BOSCH accumulator drill	-19-
Accessories optional IML-RESI F-series	-20-
Trouble shouting	-21-
Some troubles, possible cause and remedy	-21-
CE Declaration of Conformity	-21-
Your notes	-22-

INTRODUCTION

NOTES TO APPLICATION

Materials

The IML-RESI measuring instrument has been designed for use at wooden materials (trees, beams, poles). Inappropriate utilization may cause damages to the measuring system and/or the material to be examined.

IML-RESI F400

**Certainty of reading**

The measuring results gained by utilizing the IML-RESI system are not self-explanatory, they require qualified interpretation. Any conclusions with respect to the examined object (e.g. tree) will be left to the sole responsibility of the person who examines. The manufacturer of the instruments will not be responsible for wrong interpretations and conclusions, he recommends the user to attend special seminars and training.

GENERAL

Conception

It was the intention of those who developed the IML-RESI system to make available a measuring system for practical utilization, which is easy to handle, sturdy, and precise at the same time.

IML-RESI F300

**Structure of the system**

As to stability, the IML-RESI system has been designed to meet the special requirements of practical examination of trees, structural timbers, poles, and wooden structural materials. To ensure a long service life of the mechanical overload clutch, you should see to it that the clutch is not exposed to avoidable wear and tear (racing at the front or rear stop of the range of the recorder).

**Moisture**

During storage and utilization of the IML-RESI measuring system, you should generally avoid the contact of water and moisture, despite its splash-proof casing. Although the main components are protected against intake of water, you should in order to avoid malfunction or failure - consider that instruments are generally sensitive to moisture.

NOTE

As to your drill, please observe the manufacturer's safety and application instructions.

Preservation of the drilling needles

The drilling needles will have to be kept dry to prevent oxidation (e.g. rust formation), on the surface as this might lead to particles getting into the guiding mechanism of the drilling instrument during drilling, thus affecting its operability.

Especially for transportation purposes, you may put the drilling needles in a quiver for safe-keeping approx. 100 drilling needles (see 'accessories optional' at page 20).

INTRODUCTION

Maintenance

On principle, maintenance of the IML-RESI measuring instrument will be carried out by the manufacturer or by an authorized service company. According to the conditions of guarantee, the drilling instrument will have to be sent in for a first inspection after approx. 1000 measurements or after one year at the latest. Afterwards, we recommend an inspection after every 1000 measurements or at least once a year. Please always send the torque wrench (if any) along with the instrument.

Guarantee conditions

The term of guarantee for the IML-RESI system is twelve months. Guarantee is based on the condition that the instrument will be used exclusively for the purposes it has been designed for and that the safety instructions below are observed. The manufacturer will not be liable for damages owing to inappropriate utilization or handling. The warranty for defects does not cover normal wear and tear (wearing parts) nor damages resulting from inappropriate or negligent handling and excessive strain that have not been provided in the contract of purchase. Please also refer to the manufacturer's 'General Terms of Business'.

NOTE

The measuring instrument must not be opened by any person but the manufacturer or an authorized service company. Otherwise, all claims for guarantee will become extinct!

Instructions for utilization

The user accepts the manufacturer's instructions for utilization, when he operates the instrument for the first time. The instrument must not be operated, unless the user has thoroughly read the present Instructions for Use. The manufacturer will not be liable for damages owing to inappropriate handling, employment of the instrument for purposes that are not provided in the present Instructions for Use, and non-observance of the safety instructions.

Safety instructions (Safety notes for your own safety)

The instrument must not be utilized but for the purpose described in the present Instructions for Use (examination of wood or material that is similar to wood). The manufacturer (vendor) will not be liable for inappropriate employment of the Instrument. The safety instructions of the manufacturers of other devices bought along with, or required for the operation of, this instrument will have to be observed.

ATTENTION

The drill motor must not be switched on as long as a drilling needle projects from the instrument! **DANGER OF INJURY!**

In case of any manipulation of the instrument which does not necessarily require motor drive, the storage battery will have to be removed or the cable will have to be disconnected from mains supply. The safety covers will always have to be kept shut. Removal and/or bridging of safety facilities is strictly prohibited.

The maximum input speed of 400-1200 rpm must not be exceeded. The manufacturer will not be liable for inappropriate employment of the instrument. The buyer agrees to hand the present Instructions for Use over to any person whom he may let the instrument and to draw his attention to the notes concerning danger.

INSTRUCTION

Basic equipment

Pic. Shows: IML-RESI F300 incl. accessories package

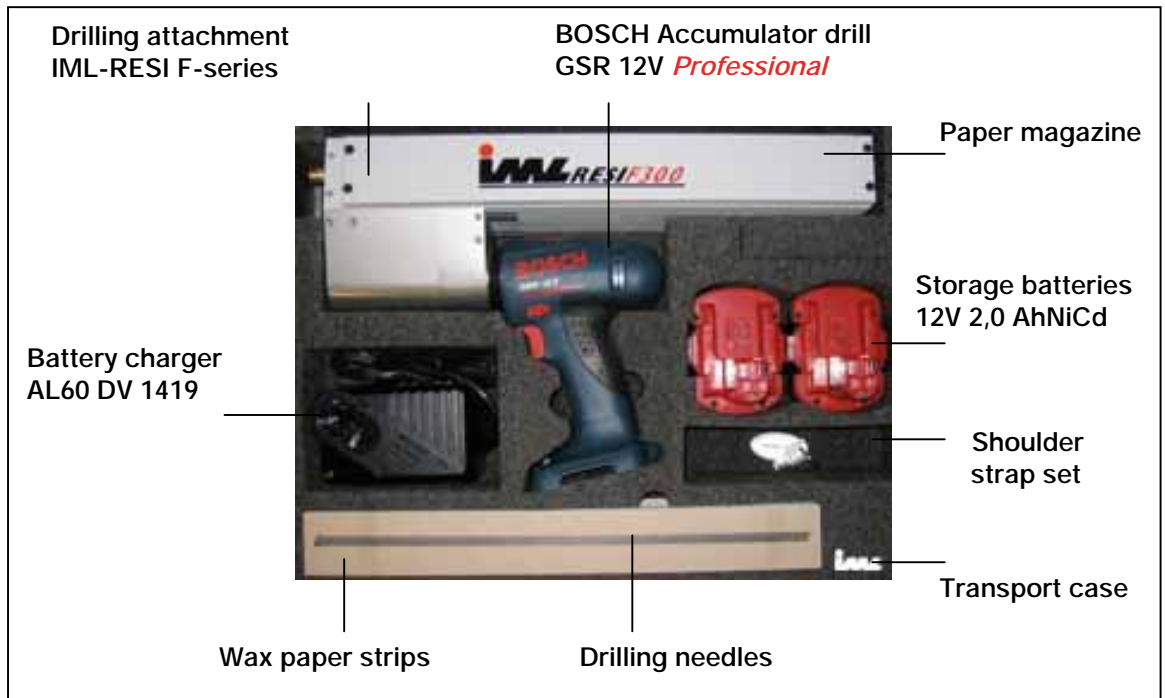

Item/Product	Item No.:
Drilling attachment IML-RESI F300/F300S	3100300/1
Drilling attachment IML-RESI F400/F400S	3100400/1
Drilling attachment IML-RESI F500/F500S	3100500/1
BOSCH Accumulator drill GSR 12V <i>Professional</i>	31000110
BOSCH Standard battery charger AL60 DV 1419	30009904
Storage battery 12V 2,0 AhNiCd	30009924
Transport case IML-RESI F300-series	3100311
Transport case IML-RESI F400-series	3100411
Transport case IML-RESI F500-series	3100511
Tool Kit	3100010
Wax paper strips F300/F400/F500	3100315/415/515
Drilling needles F300/F400/F500	3100316/416/516
Paper magazine F300/F400/F500	3100017/18/19

Optional accessories IML-RESI F-series

Item/Product	Item No.:
45°-adapter, rotatable	3100015
Serial electronic unit	3100007
Bluetooth -Electronic unit	4100007

More product selection and information on inquiry!

INSTRUCTION

Application**Utility Poles****How to hold the drilling instrument**

There is no special way of holding the IML-RESI measuring instrument. The measuring results do not depend on a certain orientation. You will, however, have to ensure your own stability during each measuring procedure, as, when the instrument penetrates the material to be examined, there will be forces acting in opposite direction of drilling.

**Examination of wooden poles**

If you examine a wooden pole, it is expedient to drill at an angle of e.g. 45°. A 45°-adapter (optional) will serve as a support of the instrument for in inclined position. Thus, by means of a special drilling needle, it will be easier to carry out the examination of wooden poles.

Execution of a measurement**Preparation of the measurement**

- charging the storage battery and insert into the BOSCH Accumulator drill
- place a wax paper strip into the IML-RESI
- check (or insert) the drilling needle

Execution of the measurement

- ensure your own stability
- set the instrument to the object to be examined
- for starting the machine, press the On/Off switch.
(The machine runs with variable speed between 0 and maximum, depending on the pressure applied to the On/off switch)
- for drilling (execution of a measurement), set the rotational direction clockwise!
- switch off drill as soon as the desired drilling depth has been reached
- after the measurement for reversing the recorder needle, set the rotational direction anticlockwise and remove the drilling needle completely from the object to be examined!

Pic. shows:

Functions of the BOSCH Accumulator drill GSR 12V *Professional*

Gear selection
(400/1200 rpm)

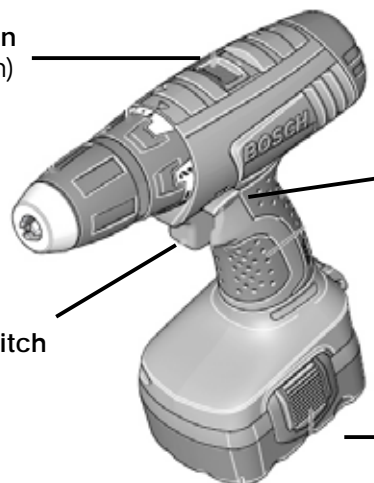

Rotational direction
switch

On/Off switch

Storage battery

INSTRUCTION

Pre-adjustments

Adjusting the advanced speed stage of the accumulator drill

Two speed ranges can be pre-selected on the accumulator drill with the gear selection:

- 1st gear: low rotational speed (400 rpm)
Used for **tree examination** (higher resolution)
- 2nd gear: high rotational speed (1200 rpm)
Used for **utility poles**

Adjusting the sensitivity

The setting wheel for adjustment of sensitivity is installed at the rear of the IML-RESI attachment. The stages of sensitivity are marked by the **numbers 1 and 2**.

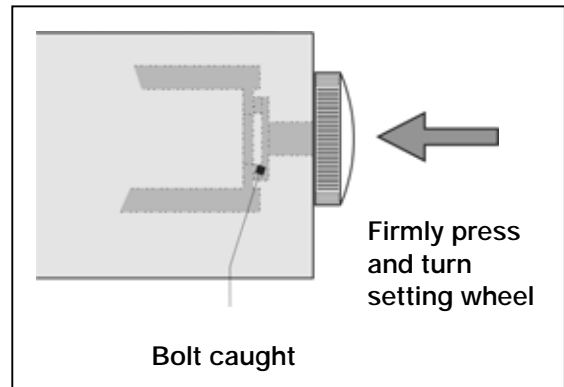
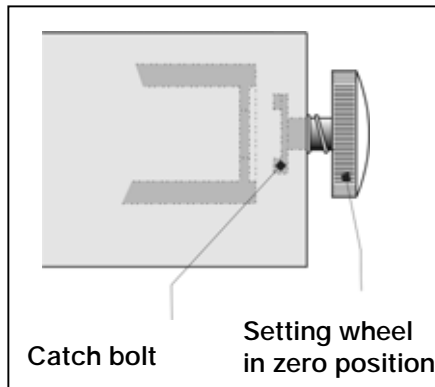

As long as the setting wheel is not pressed, it is in zero position!

To modify the sensitivity, move the slide to rear end position. Slightly press the setting wheel against the casing and turn it until the bolt catches perceptibly. Now press the wheel firmly and set the desired sensitivity by turning it. Then release the setting wheel; it returns to zero position.

Sensitivity stages:

- Stage 1: soft wood
- Stage 2: hard wood

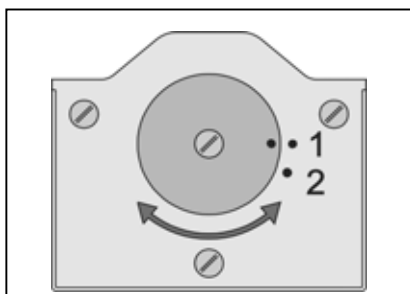

INSTRUCTION**Sensitivity stages**

The following table is a guideline for the selection of the proper sensitivity stage. Owing to the varying characteristics of wood, however, you will have to determine the correct stage in each case. For this purpose, please see the tables of bulk density in a wood manual.

Table of approximate values

Object	Species	Usual sensitivity stages	
		usually	possibly
Standing Trees	Carpinus, Quercus, Fagus, Acer...	2	1
	Platanus, Castanea...	2	
	Abies, Pinus, Picea, Tilia, Betula, Aesculus...	1	
	Populus, Alnus...	1	
Structural Timbers, Poles...	Quercus...	2	
	Picea, Pinus, Abies, Larix, Thuja...	1	

Depending on the circumstances, you may select a lower or higher stage than the one indicated above.

INSTRUCTION

Insert or exchange the wax paper strip

Wax paper strip



Open the plastic cover



Open the plastic cover to remove the old wax paper strip: slightly bend the strip with your fingers to make it slide off the guiding rails, then pull the strip upwards.

To place a new paper strip, slightly bend it to match the curve of the introduction slot of the IML-RESI attachment.

Now, introduce the wax paper strip through the introduction slot into the guiding rails. Perhaps you will have to lift up the recorder stylus a little to enable the paper strip sliding through.

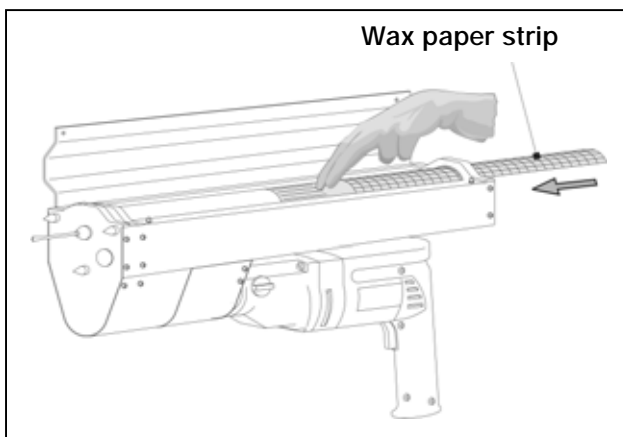
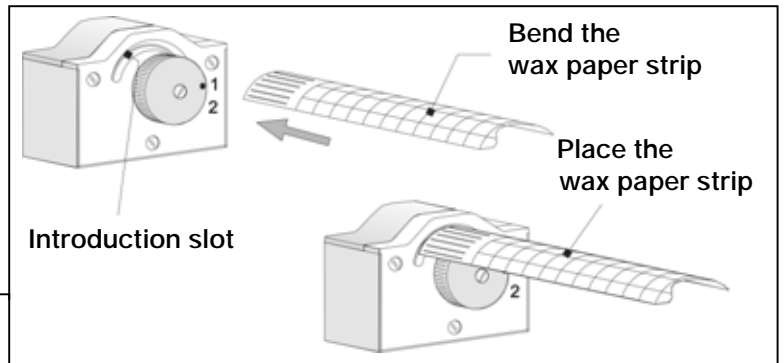

Push the wax paper strip slowly forward by hand.

Shut the plastic cover!



INSTRUCTION

Exchanging the drilling needle

Drilling needle

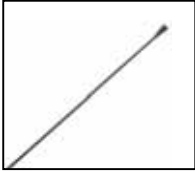

To ensure correct measuring results, you should check the drilling needle with respect to wear after every tenth drilling. For exchange of the needle, open the top cover and remove the wax paper strip by pulling it upward. Next, take off the gray security label (cf. section 'exchanging the wax paper strip')!

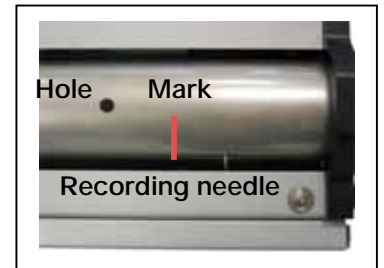
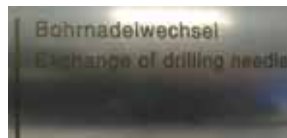

Gray security label

**ATTENTION**

During positioning of the recording needle towards the mark be aware that the drilling needle will rotate and move forward!

Rotational direction switch for changing the drilling direction of the needle



Forward recording needle to the intended mark by operating the On/Off switch (+- mark). You may see the clamping screw through the hole on top of the paper cover.

Push red rotational direction switch in middle (neutral) position. Now, take off the storage battery or the powerpack connection cable!

Open the clamping screw with the socket screw key - direction clockwise (about 2 turns). Now, you can release the drilling needle forward and replace it with the new one.

Socket screw key



Use the hexagon key 2.5 mm to open allen screw (about 2 turns)!

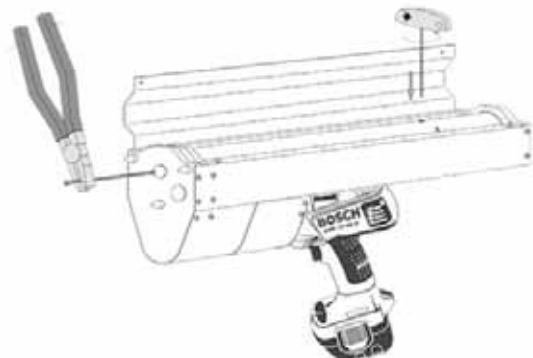

INSTRUCTION

Exchanging the drilling needle

Insert the new drilling needle by hand into the instrument up to the stop.
First slightly tighten the clamping screw by means of the hexagon socket screw key, then firmly tighten it by turning it approx. 45° clockwise. Fix a new security label if available.

Place a new wax paper strip, shut the plastic cover, choose the drilling by operation the rotational direction switch, insert the storage battery.

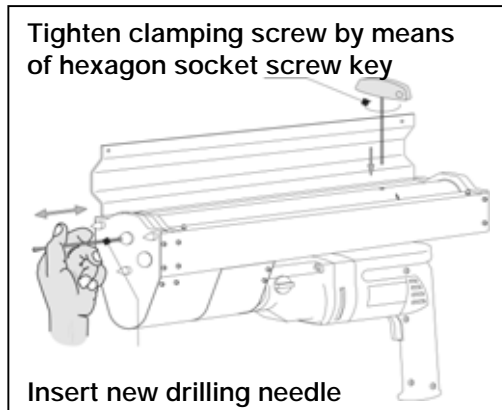

It might happen, in rare cases, that the drilling needle has to be exchanged while the drive shaft is in front position (for instance if the drilling needle is deformed or broken). In that case, proceed as described above but previously move the drive shaft to front position.

NOTE

To exchange a broken drilling needle, the recording needle will always have to be moved in front position!

CAUTION

If you have to move the recording needle in the front position - be careful - **INCREASED DANGER OF INJURY!**

INSTRUCTION

Maintenance works

NOTE

Some of the maintenance works described below can only be carried out by means of the professional **TOOL KIT**, which is included in the scope of delivery!

Lubrication of the gear wheels

Gear wheel



The gear wheels will have to be checked for defects after approximately 200 measurements. First, disconnect the instrument from power supply and remove the **safety cover**. In general, remove all kinds of soil. Now, you may check the gear wheels.

Tools: Oil can (TOOL KIT)

Oil can



If the gear wheels are free from defects, slightly lubricate them. Place the safety cover and connect the instrument to power supply.

If the gear wheels are damaged, send the instrument to the manufacturer for repair!

Replacing the safety pin



The safety pin have to be replaced, if:
- the drilling needle does not rotate and the slide does not move anymore!

Tools: Hammer and pin punch (TOOL KIT)

Pin punch
& hammer

Remove safety covers 1 and 2 and disconnect the drill from the drive shaft. Remove the remaining part of the safety pin by means of the pin punch supplied. Pull the hexagon bolt out of the drive shaft.

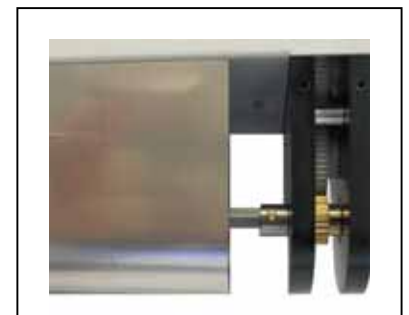
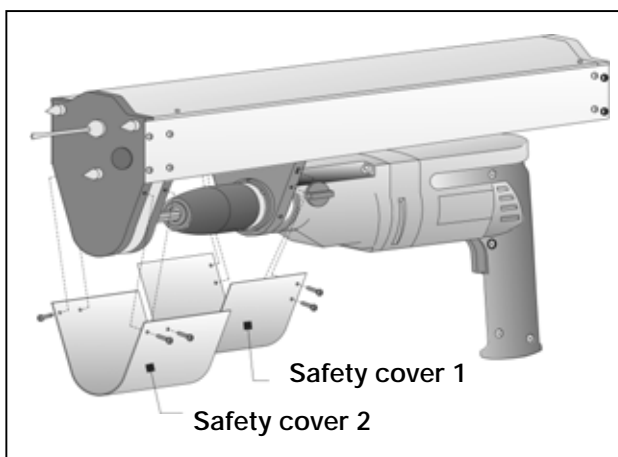

INSTRUCTION

Replacing the safety pin

Insert the hexagon bolt into the drive shaft, ensuring that the markings of the drive shaft and of the hexagon bolt coincide. Now drive in the new safety pin by means of a hammer. Re-attach the drill as described on page 19.

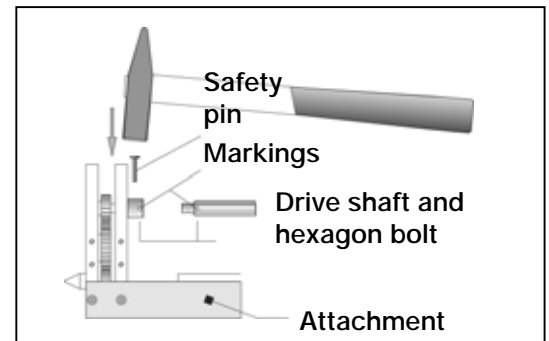
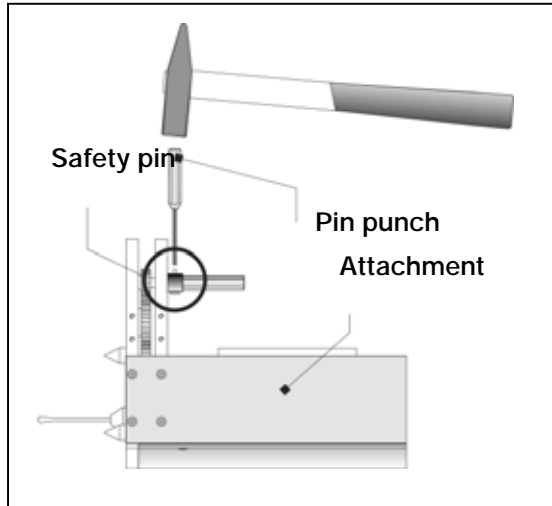

Overload clutch

The overload clutch is worn out, if:

- the slide with the recording needle does not move from the rear position!
- the recording needle does not move forward at uniform speed!

Counter wrench
& screw driver

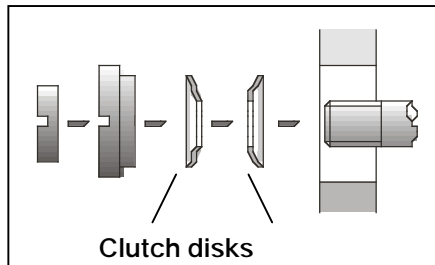
Tools:

Adjusting wrench, sickle spanner,
counter wrench, screw driver,
hexagon socket screw key

Hex. socket
screw key



Adjusting the overload clutch by means of the sickle spanner

- if the slide is in rear position, move it forward by 2 to 3 mm
- remove the storage battery for safety reasons
- remove the clutch cap
- fix the adjusting nut by means of the sickle spanner and loosen the counter nut by means of the counter wrench and turn it out a little
- loosen the adjusting nut
- insert the small hexagon socket screw key into the slot on the one side of the adjusting nut and turn it slowly (1/8 rotations) by means of the sickle spanner
- stop the spindle by means of the screw driver and tighten the adjusting nut
- fix the adjusting nut by means of the sickle spanner and firmly tighten the counter nut by means of the counter wrench!

INSTRUCTION

Adjusting the overload clutch by means of the sickle spanner

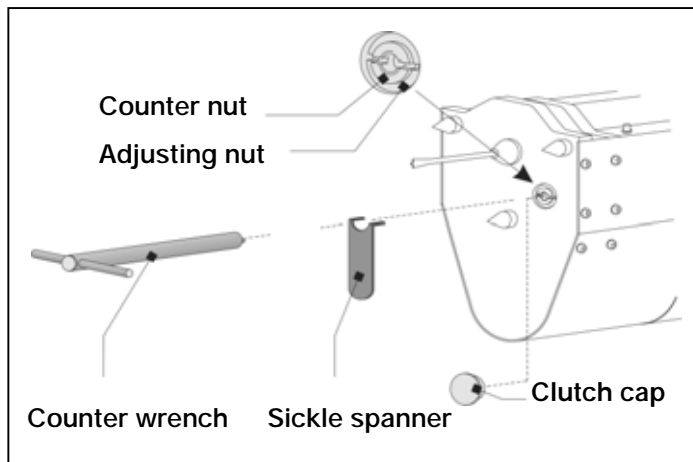

Adjusting the overload clutch by means of the torque wrench (TOOL KIT)

- if the slide is in rear position, move it forward by 2 to 3 mm
- remove the storage battery for safety reasons
- remove the clutch cap
- set torque wrench onto the adjusting nut and fix the adjusting nut by means of handle (light)
- pass the counter wrench through the opening in the torque wrench, loosen the counter nut and unscrew it a little
- loosen the adjusting nut a little by means of the torque wrench, then re-tighten it slowly by means of the rotating sleeve (black) until the rotating sleeve races (shortly move the rotating sleeve before using it)
- grip the adjusting nut by means of the handle (light) of the torque wrench and firmly tighten the counter nut by means of the counter wrench, ensuring that the adjusting nut does not turn during this procedure!

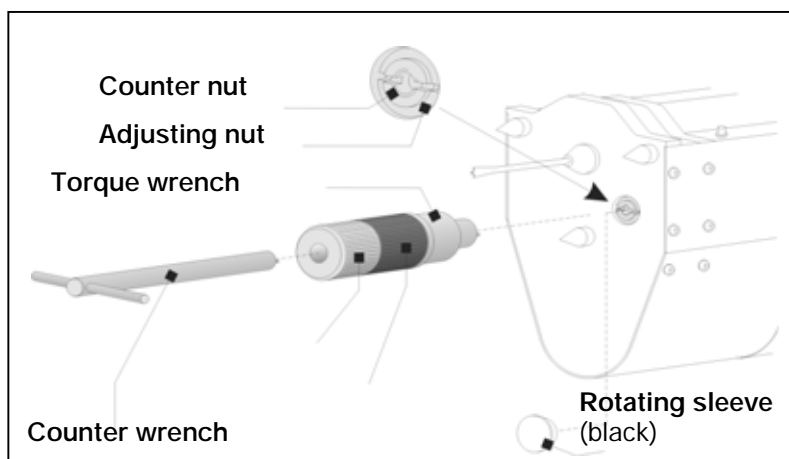

INSTRUCTION**Exchanging the clutch disks**

- if the slide is in rear position, move it forward by 2 to 3 mm
- remove the storage battery for safety reasons
- remove the clutch cap
- set torque wrench onto the adjusting nut and fix the adjusting nut by means
- pass the counter wrench through the opening in the torque wrench and loosen the counter nut
- unscrew both nuts and remove worn clutch disks
- if there is a hexagon nut, unscrew it by means of the socket wrench
- place new clutch disks
- screw in the adjusting nut: tighten it slowly by means of the rotating sleeve (black) of the torque wrench until the rotating sleeve races, simultaneously fixing the spindle by means of a screw driver
- place the counter nut, fix the adjusting nut by means of the handle (light) of the torque wrench and firmly tighten the counter nut by means of the counter wrench
- re-connect the instrument with the power supply!

ATTENTION

Check clutch setting if the drilling advance is not regular. A clutch that has been set too firm may lead to damages to the instrument. To ensure a long service life of the clutch disks, you will have to see to it that it does not unnecessarily race at the front or rear stop of the range of the recording needle!

INSTRUCTION

Mounting the paper magazine

(Item No.: 3100017/18/19)

Paper magazine

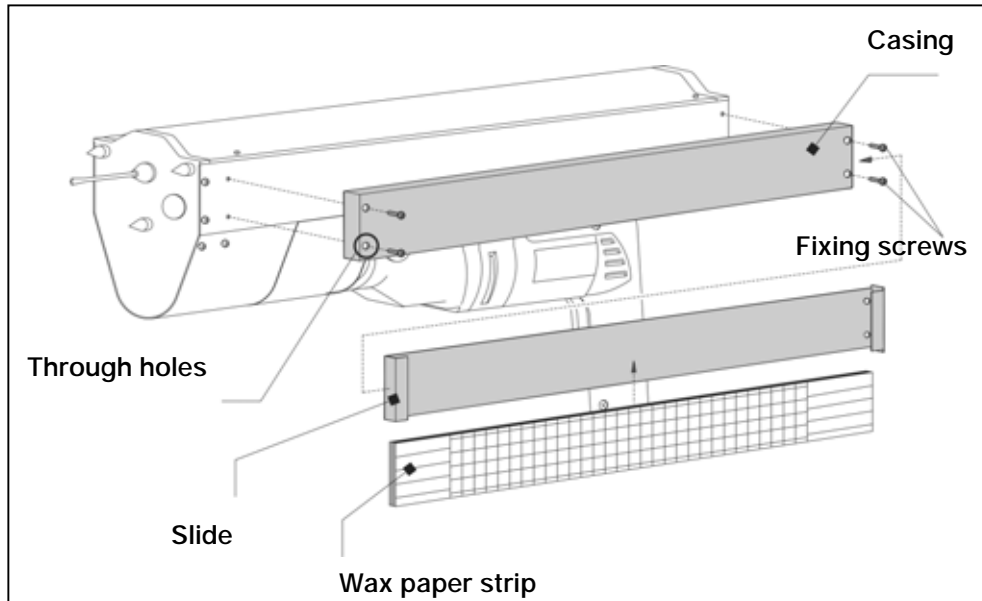
**Mounting:**

- remove the 4 fixing screws from the IML-RESI
- place the casing of the paper magazine upon the IML-RESI
- attach the casing of the paper magazine to the IML-RESI by means of the 4 fixing screws
- place the slide with the wax paper strips into the casing of the paper magazine
- close the holes on the casing by means of the caps supplied!

NOTE

It is advisable to glue the caps, in order to prevent penetration of water and dirt into the paper magazine!

Paper magazine

- inclusive slide for safe-keeping approx. 50 wax paper strips



INSTRUCTION

Mounting the 45°-adapter, rotatable (optional)

(Item No.: 3100015)

45°-Adapter

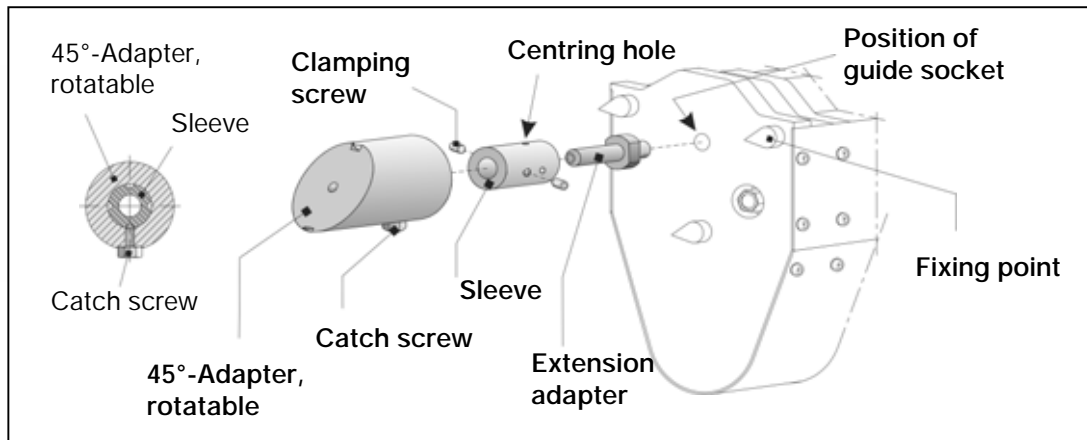
**Mounting:**

- disconnect the drill from the power supply for safety reasons
- remove standard drilling needle
- remove standard guide sleeve by turning it with pliers
- mount the extension adapter instead of the guide sleeve
- attach the sleeve on the extension adapter
- one of the centering holes must point vertically upward
- fix the sleeve by means of the 2 clamping screws

ATTENTION

- Insert the drilling needle for 45°-adapter (length: 389 mm/499 mm/609 mm)!
- Never use a standard drilling needle and the 45°-adapter!!!

- attach the rotatable 45°-adapter to the sleeve so as to snap in the centering hole
- re-connect the instrument to power supply!

45°-Adapter, rotatable



Sleeve



Extension adapter

**NOTE**

In case the fixing points should be obstructive in certain situations during the drilling, with the 45°-adapter, they may be replaced by the screw supplies.

INSTRUCTION

Attaching the BOSCH accumulator drill

First place the adapter plate. In case of need, use the reducing ring supplied. The IML special adapter (Euro norm: Ø 48 mm/43 mm) is still attached on the new BOSCH Accumulator drill GSR 12V *Professional*.

Place the reducing ring on the drill, then slide the adapter plate over the ring. Fix the adapter plate to the drill by means of clamping screws.

BOSCH GSR12V Professional



Special adapter



Adapter plate

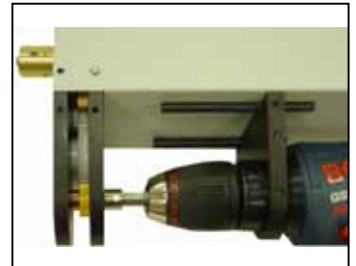
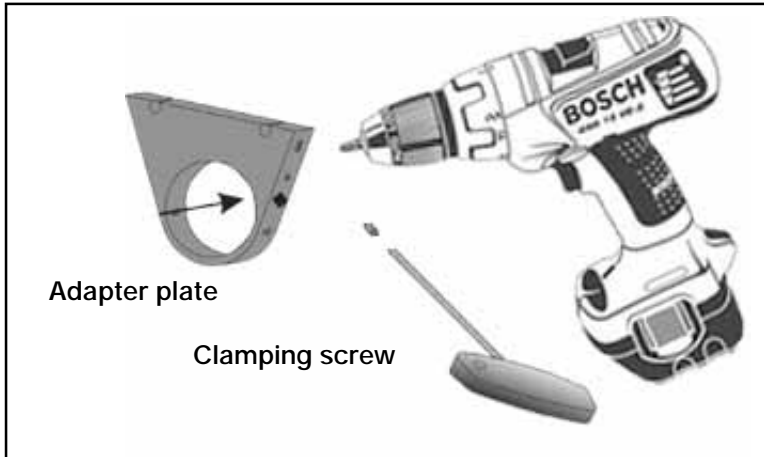

Place the drill thus prepared on the guiding rails of the IML-RESI attachment and slide the drill forward.

Fix the drill to the adapter plate by means of the clamping screws on both sides. When tightening the drill holder, pay attention to the exact position of the hexagon bolt in the drill holder.

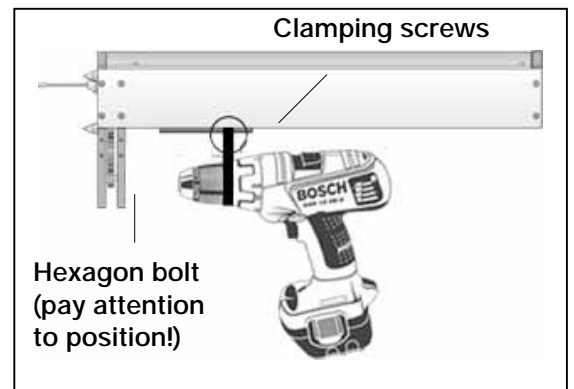
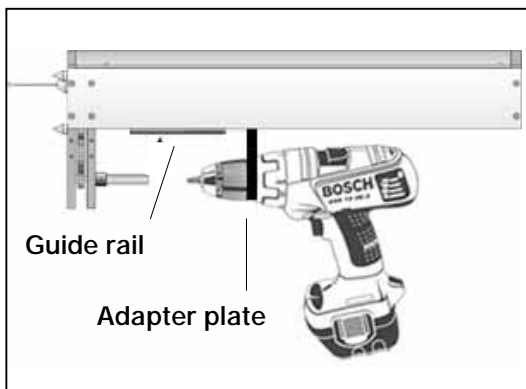

NOTE

Tighten drill holder very firmly (perhaps by means of pliers)!

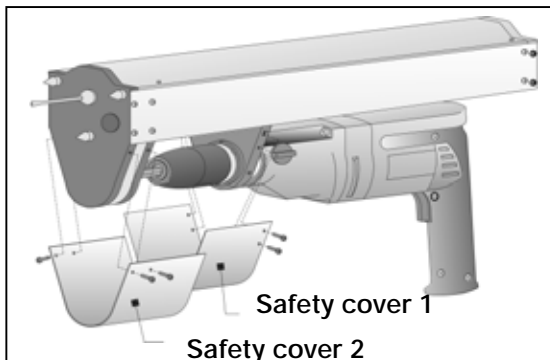

Finally, place **Safety cover 1**, and then **Safety cover 2!**

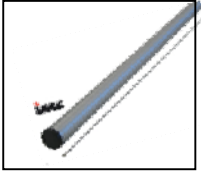
INSTRUCTION**Accessories optional IML-RESI F-series****Quiver****Quiver**

for safe-keeping approx. 100 drilling needles
Item No.: 3103016

TOOL KIT**TOOL KIT**

for all upgrades and small repair works of the IML-RESI F-series
Item No.: 3100010

Paper magazine

for safe-keeping approx. 50 wax paper strips
Item No.: 3103017/18/19

Car-charger**BOSCH Standard battery charger AL60 DV 1419**

Storage batteries 7,2V-14,4V
Item No.: 31000111

Car-battery charger AL60 DC 2422

12V/24V – Storage batteries 7,2V-14,4V
Item No.: 30009913

Charger**BOSCH Quick battery charger AL60 DV 1450**

Storage batteries 4,8V-14,4V
Item No.: 30009911

Storage battery 12V 1,5 AhNiCd

Item No.: 30009925

Storage battery**Storage battery 12V 2,0 AhNiCd**

Item No.: 30009926

Storage battery 14,4V 2,4 AhNiCd

Item No.: 30009928

Storage battery**Drilling needles IML-RESI F300 for 45°-adapter (length 389 mm)**

Item No.: 3100317

Drilling needles IML-RESI F400 for 45°-adapter (length 499 mm)

Item No.: 3100417

Drilling needles IML-RESI F500 for 45°-adapter (length 609 mm)

Item No.: 3100517

More product selection and information on inquiry!

INSTRUCTION

Trouble shouting (Some troubles, possible cause and remedy!)

The drilling needle rotates, but the slide does not move forward from the rear position!

- switch on the drill several times in forward running and see whether the slide moves!
- remove clutch cap in the front plate and turn the central spindle clockwise a little by means of a screw driver.
- if the problem occurs frequently, the clutch will have to be re-adjusted, cf. section 'overload clutch'!

The drilling needle rotates, but the slide does not move forward nor backward from any position!

- re-adjust the clutch as described in the section 'overload clutch'!

The drilling needle does not rotate, and the slide does not move at all!

- the drill has not been set to any transmission stage!
- the safety pin has sheared off owing to overload, cf. section 'replacing the safety pin'!

The drilling needle does not rotate, the slide does not move, and a rattling noise is to be heard during operation of the drill!

- the drill holder of the drill has opened
- the gearbox of the IML-RESI is damaged, please contact your dealer!

The drilling needle may jam in the material to be examined, if:

- the power of your drill is too low
- it hits hard, non-wooden materials (stone, splinter...)
- a drilling process in green wood has been stopped and re-started more than several minutes later and the needle has stuck in the wood during this time
- the drilling instrument has been canted during the measuring process

If you should not be able to remove the needle from the drill hole by turning it, you will have to remove it from the drill, cf. section 'exchanging the drilling needle'!

If you should not succeed in removing the needle from the drill holder this way, you will have to cut it off between the wood and the drilling instrument. The part that remains in the drill holder will be removed as you would do for usual exchange of the drilling needle and replaced by a new drilling needle!

NOTE

The measuring instrument must not be opened by any person but the manufacturer or an authorized service company. Otherwise, all claims for guarantee will become extinct!

CE Declaration of Conformity

We declare on our own responsibility that the above product complies with the following standards or normative documents: EN 50 144, EN55 014 (accumulator tools) EN 60 335, EN 55 014 or EN 55 011, EN 60 555 (storage battery chargers) according to the regulations of the guidelines 73/23/EWG, 89/336/EWG, 89/392/EWG, 98/37/EG.

INSTRUCTION

NOTES